

# PG56S-PM-ST

## 行星齿轮箱上下版结构粉末冶金 56(mm)

Planetary gearbox powder metallurgy Ver.56(mm)



外壳材质 Housing Material	输出轴承 形式 Bearing at output	径向负载 (N) Radial load (10mm from flange)	轴向负载 (N) Shaft axial load	主轴最大承受 压入力 (N)Shaft press fit force max	径向间隙 (mm) Radial play of shaft	轴向间隙 (mm) Thrust play of shaft	背隙 (无负载时) (°) Backlash at no-load
粉末冶金 Powder metallurgy	滚珠轴承 Ball bearing	≤250	≤100	≤1000	≤0.08	≤0.5	≤2.5°

\*负载与转速有关,具体数据需参考实际情况。

\*Load relates to speed, actual value depends on different situation.

### 外型图/Mechanical Dimension

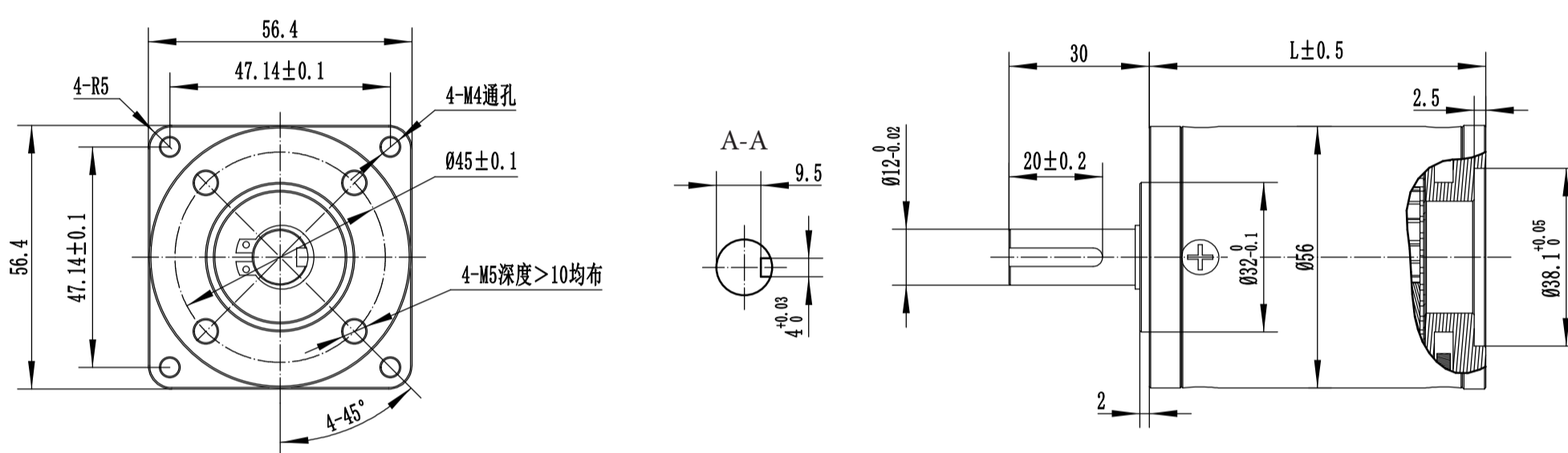

Unit:mm

### 标准减速比形式/Gearbox Specifications

减速比 Reduction Ratio	实际减速比 Exact Reduction Radio	额定允许负载 Rated Tolerance Torque (Nm)	瞬间允许负载 Momentary Tolerance Torque (Nm)	效率 Efficiency (%)	长度 Length (mm)	重量 Weight (g)	减速比级数 Number of gear trains
1:3.6	1:3 <sup>3</sup> / <sub>5</sub>	10	30	90%	48	430	1
1:4.25	1:4 <sup>1</sup> / <sub>4</sub>						
1:5.33	1:5 <sup>1</sup> / <sub>3</sub>						
1:12.96	1:12 <sup>24</sup> / <sub>25</sub>	20	50	81%	60	570	2
1:15.3	1:15 <sup>3</sup> / <sub>10</sub>						
1:18.06	1:18 <sup>1</sup> / <sub>16</sub>						
1:19.2	1:19 <sup>1</sup> / <sub>5</sub>						
1:22.67	1:22 <sup>2</sup> / <sub>3</sub>						
1:28.44	1:28 <sup>4</sup> / <sub>9</sub>						
1:46.66	1:46 <sup>82</sup> / <sub>125</sub>	40	70	72%	72	710	3
1:55.08	1:55 <sup>2</sup> / <sub>25</sub>						
1:65.03	1:65 <sup>1</sup> / <sub>40</sub>						
1:69.12	1:69 <sup>3</sup> / <sub>25</sub>						
1:76.77	1:76 <sup>49</sup> / <sub>64</sub>						
1:81.6	1:81 <sup>3</sup> / <sub>5</sub>						
1:96.33	1:96 <sup>1</sup> / <sub>3</sub>						
1:102.4	1:102 <sup>2</sup> / <sub>5</sub>						
1:120.89	1:120 <sup>8</sup> / <sub>9</sub>						
1:151.70	1:150 <sup>46</sup> / <sub>27</sub>						